

ラック形カッタ

●タイプ別寸法表

JIS1形

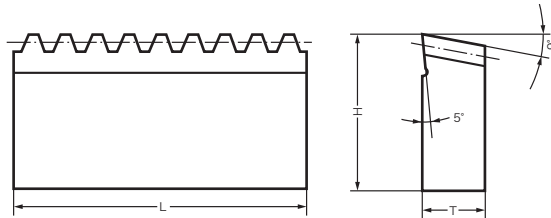

Unit : mm

モジュール (m) Module	H	T	L	歯数 (z) No. of teeth
1	55	20	60	18
1.25	55	20	60	14
1.5	55	20	60	12
1.75	55	20	60	10
2	55	20	65	10
2.25	55	20	75	10
2.5	55	20	75	9
2.75	55	20	80	9
3	55	20	85	9
3.25	55	20	85	8
3.5	55	20	90	8
3.75	55	20	95	8
4	55	20	105	8
4.5	55	25	105	7
5	55	25	115	7
5.5	60	25	125	7
6	60	25	135	7
6.5	60	25	145	7
7	60	25	155	7
8	65	25	180	7
9	65	25	200	7
10	65	25	190	6
11	70	25	210	6
12	70	25	230	6
14	75	32	265	6
16	85	32	300	6
18	90	32	280	5
20	95	32	310	5
22	100	32	270	4
25	110	32	310	4

ラック形カッタ

●タイプ別寸法表

JIS 2形

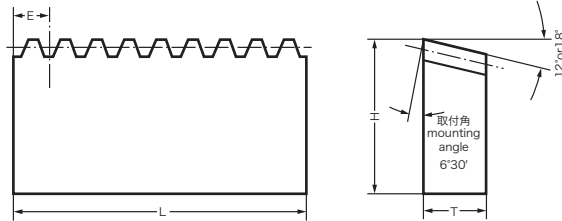

Unit : mm

モジュール (m) Module	H	T	L	歯数 (z) No. of teeth	E
1	48	20	76	24	3.5
1.25	48	20	94	24	4
1.5	48	20	113	24	5
1.75	48	20	132	24	6
2	48	20	132	21	6.5
2.25	48	20	135	19	7.5
2.5	48	20	150	19	8
2.75	48	20	156	18	9
3	48	20	170	18	10
3.25	48	20	174	17	10.5
3.5	48	20	176	16	11
3.75	48	20	177	15	12
4	48	20	176	14	12.5
4.5	48	20	170	12	14.5
5	48	20	173	11	16
5.5	48	20	174	10	18
6	58	20	153	8	20
6.5	58	20	165	8	21
7	58	20	176	8	22
8	68	23	176	7	25
9	68	23	197	7	28
10	68	23	219	7	31
11	78	23	241	7	34
12	88	23	224	6	36
14	88	23	216	5	42
16	98	23	246	5	48
18	98	23	219	4	53
20	108	23	243	4	59
22	123	23	266	4	64
25	128	23	223	3	72



ラック形カッタ

●タイプ別寸法表

JIS3形

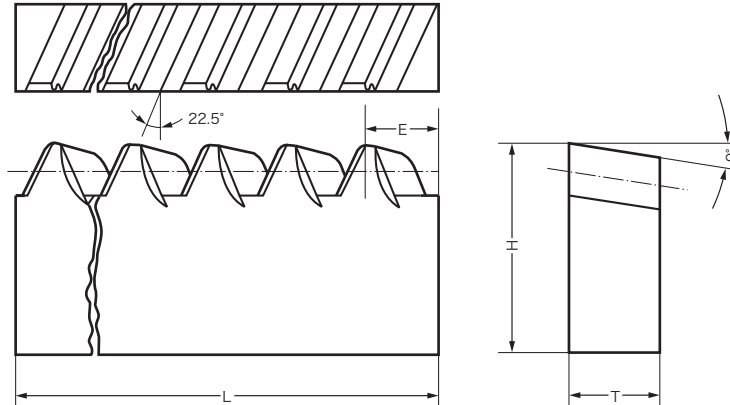

サンダーランド形 SUNDERLAND TYPE

Unit : mm

モジュール (ms) module			H	3-A1 type				3-A2 type			3-B1 type			3-B2 type		
1	2	3		T	L	歯数 (z) No. of teeth	T	L	歯数 (z) No. of teeth	T	L	歯数 (z) No. of teeth	T	L	歯数 (z) No. of teeth	
1.5			55	25	75	12										
	1.75		55	25	85	12										
2			55	25	95	12										
	2.25		55	25	95	11										
2.5			55	25	95	10										
	2.75		60	25	100	10										
3			60	25	100	9										
		3.25	60	25	105	9										
		3.5	60	25	115	9										
		3.75	60	25	120	9										
4			60	32	115	8	40	120	8	32	165	12	40	170	12	
	4.5		65	32	130	8	40	135	8	32	185	12	40	190	12	
5			65	32	140	8	40	145	8	32	205	12	40	210	12	
	5.5		65	32	155	8	40	160	8	32	225	12	40	225	12	
6			65	32	165	8	40	170	8	32	225	11	40	225	11	
		6.5	65	32	180	8	40	185	8	32	220	10	40	225	10	
	7		65	32	190	8	40	195	8	32	235	10	40	240	10	
8			65	32	190	7	40	195	7	32	265	10	40	270	10	
	9		65	32	185	6	40	190	6	32	270	9	40	275	9	
10			65	32	205	6	40	205	6	32	300	9	40	300	9	
	11		70	32	220	6	40	225	6	32	325	9	40	330	9	
12			70	32	240	6	40	245	6	32	355	9	40	355	9	
	14		75	40	280	6	45	285	6	40	370	8	45	370	8	
16			80	40	320	6	45	320	6	40	370	7	45	370	7	
	18		85	40	355	6	45	355	6	40	410	7	45	415	7	
20			90	40	390	6	45	395	6	40	455	7	45	455	7	
	22		95							40	430	6	45	430	6	
25			100							40	485	6	45	490	6	



ラック形カッタ

●タイプ別寸法表

大型マーグラックカッタ

Unit: mm

モジュール (m) module	H	T	L	歯数 (z) No. of teeth
26	133	23	233	3
28	138	23	249	3
30	143	23	266	3
32	145	23	281	3
33	148	23	290	3
34	152	28	297	3
36	157	28	205	2
38	162	28	215	2
40	167	28	225	2

大型単刃マーグカッタ

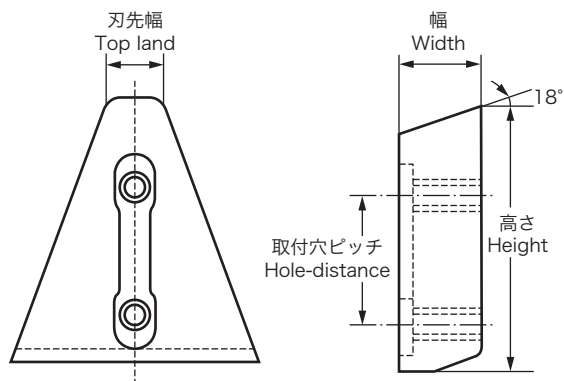

Unit: mm

ホルダータイプ	モジュール (m) module	高さ H	幅 W
D	20~24	105	28
E	24~33	95	28
F	33~40	113	28
J	42~50	128	28

